



An  *Direct Inc. Company*

ITC 204

Product Sizing Capacity:

Width: 1-20" – Length 3-12" (DOT)

+600'/200M Minute

Innovative Turn Conveyor - Designed to accommodate your needs – In a moment go from “turn-over” to “straight through” without tools – Simple adjustment and maintenance – Ball bearing turntable head ensures smooth adjustment.

EASY Operation and Maintenance

Engineered for simple trouble-free operation,
Roll it up and go...

- ½ HP DC Drive
- Self-tensioning belts
- Self-adjusting gap control
- Powder coated finish
- See thru poly guards
- “Pass-through” or “turn”
- Tool-less
- Easy to maintain
- Drive reversible
- Casters
- Leveling pads

Options:

- Extended height
- Speed Following

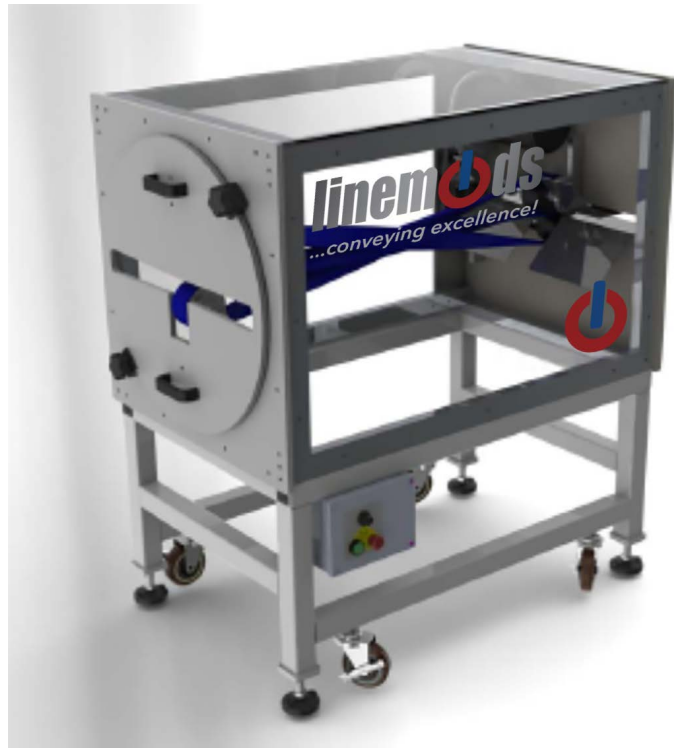

General Machine Specs:

Weight: 475 Lbs.
Power: 110V/230V Single
Phase (6/3 amp)
Air: NA

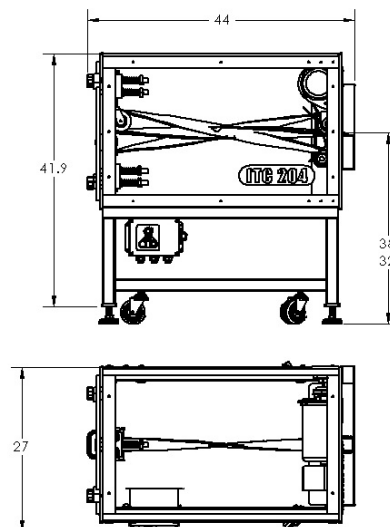

For more information, visit www.smsdirectinc.com or call 815-524-7700