

VPS 209

20" x 9' Premium Heavy-Duty Stacker

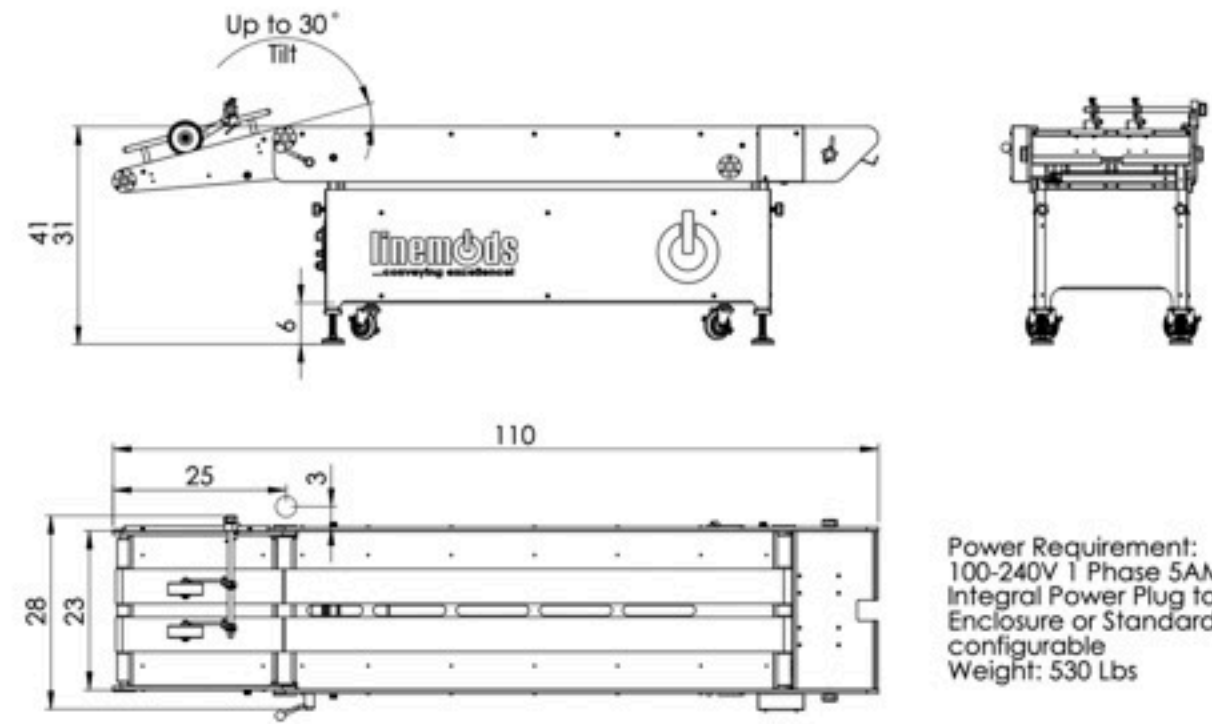

VPS 309

30" x 9' Premium Heavy-Duty Stacker

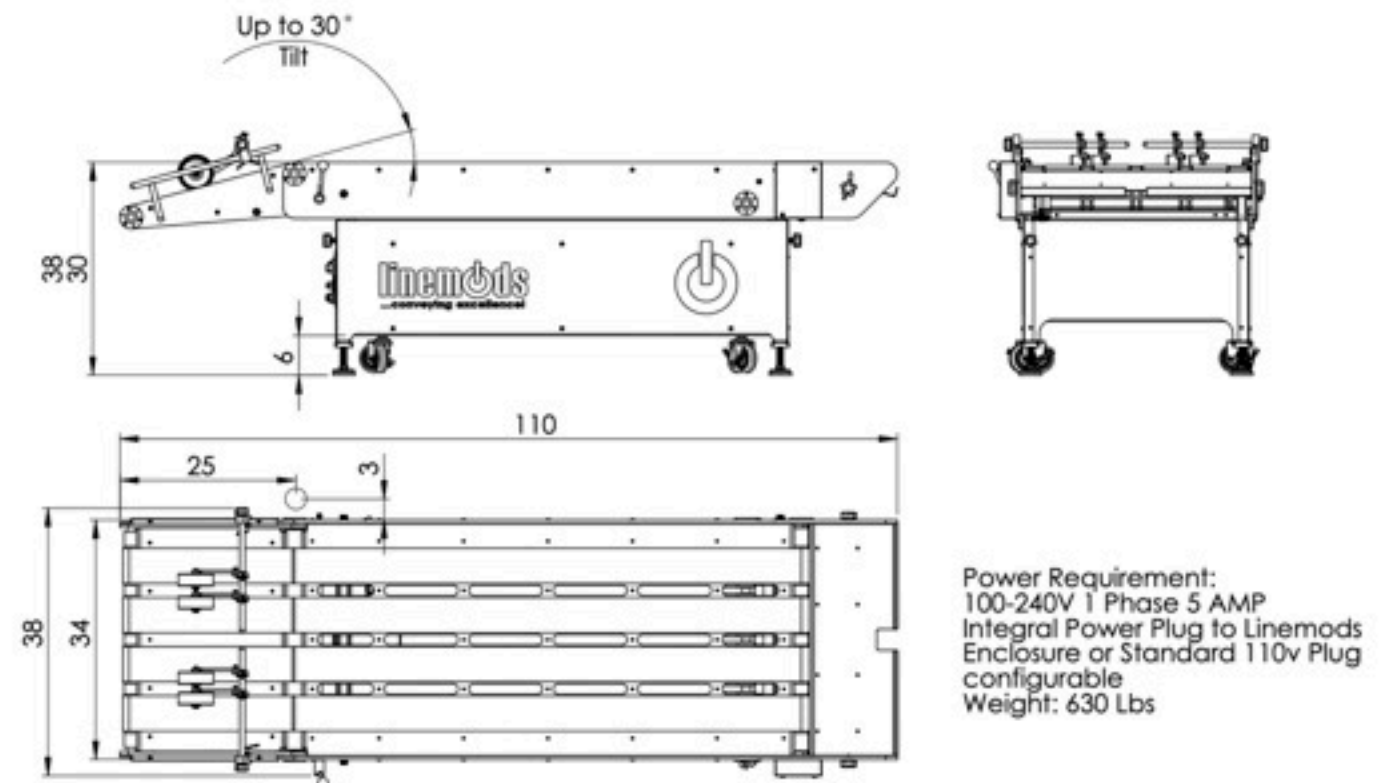

Accessories

Batch Head

Ball Register Guide

Pressing Head 30

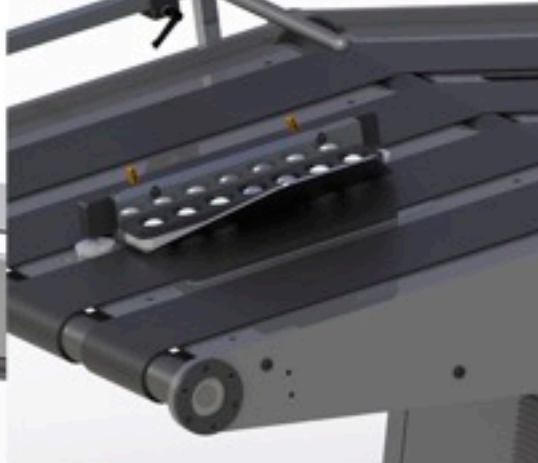

Attributes

- > Stepper drive
- > Maintenance free
- > Self-tensioning
- > Plugs directly into CNV receptacle on most Linemods machinery

Optional Accessories

- > Start, stop, feed and speed pendant
- > Right angle ball register for left/right angle operation
- > Batching head- Staggered shingle
- > Light tower
- > Standalone 110v power and I/O cables
- > Presser head - Compresses product-preparation for packing

Optional Features

Speed shift controls (integral hardware/software options)

Product Capacity

Width: 20" OR 30" width capacity x 9' long

Max Speed: 120' minute

Electrical: 100-240v 1 Ph / 5amps (configurable)